

SITEX® Teeth Coupling



**SITEX®**

**SITEX<sup>3/4</sup> 7 =**

## SITEX® teeth couplings

### Description

SITEX® couplings consist of two toothed hubs which are connected with one internally toothed sleeve. The hubs are made of steel and the teeth, which are both profiled and section crowned,

are obtained from milling. The sleeve is manufactured from stabilized 6.6 superpolyamide resin.

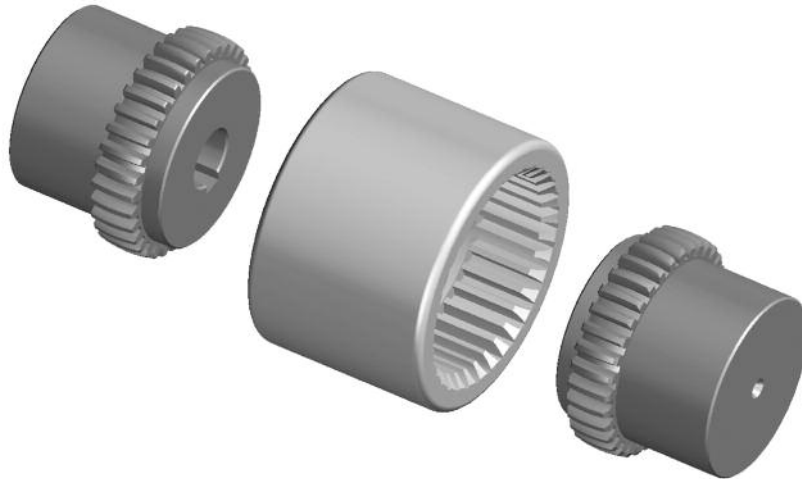

### Features

SITEX® couplings are members of the elastic coupling family range. Sitex couplings are well suited for applications with axial, radial, and angular displacement of the connected shafts. The double cardanic action eliminates the imposition of loads on the shafts which results from radial and axial misalignment.

The torsional rigidity of the sleeve prevents angular speed variation.

The combination of steel hubs with Polyamide sleeve makes the coupling maintenance and lubrication free.

The particular toothed profile prevents contact of tooth edges with the sleeve, ensuring long life of the coupling.

### Performance

Mounting can be in both the horizontal and vertical planes. Installation is simple and quick, which lowers installation costs.

The coupling is suitable for operating in temperatures ranging from - 25°C to + 90°C.

For short intervals, temperatures of + 125°C can be tolerated. Components of the coupling are resistant to all types of lubricants and hydraulic fluids.

### ATEX 94/9/EC compliance

It is possible to ask for specific certification for use in hazardous area according to EC standard 94/9/EC. TRASCO couplings are available with specific mounting/operating instruction manual and conformity. For information, please contact our technical office.

**Dimensional characteristics**

Due to compact dimensions and excellent performances, SITEX® couplings may be used in a wide range of applications. Couplings are available from stock, both the standard and the "long" hub execution, which entirely covers the motor shaft.

SITEX hubs are available with certain stock bores as listed below. The standard solid hub has a pilot center concentric to the hub OD and can be bored to specific needs.

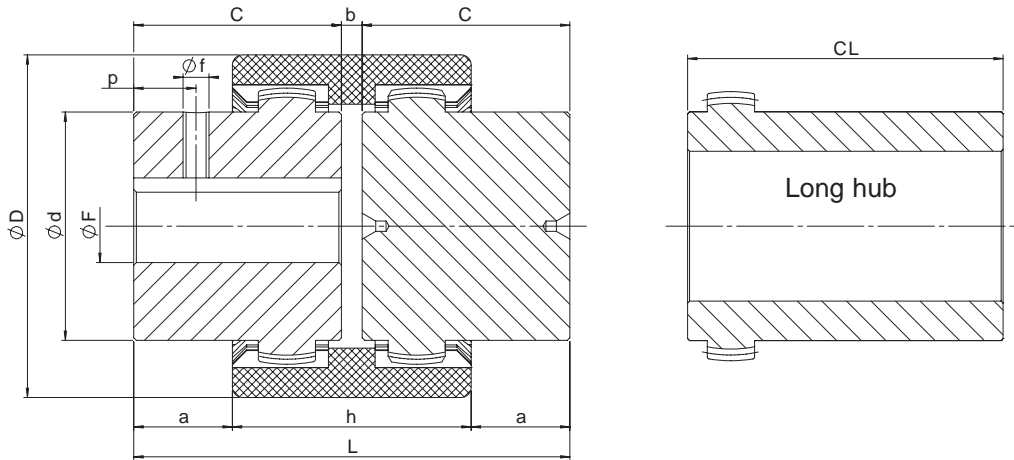

Size	D [mm]	d [mm]	F (H7)			C [mm]	CL [mm]	b [mm]	a [mm]	h [mm]	L [mm]	f [mm]	p [mm]	W** [kg]	J** [kg m <sup>2</sup> ]
			min	max	UNI keyway and set-screw* [mm]										
0.5/14	40	24,5	8	14	11 - 14	23	30	4	6,5	37	50	M5	6	0,18	0,000026
19	48	30	8	19	11 - 14 - 19	25	-	4	8,5	37	54	M5	6	0,24	0,000054
2/24	52	35	11	24	14 - 19 - 22 - 24	26	50	4	7,5	41	56	M8	6	0,30	0,000088
3.5/28	66	43	11	28	16 - 19 - 22 - 24 - 28	40	60	4	18,5	47	84	M8	10	0,73	0,000312
5/32	76	50	14	32	22 - 24 - 28 - 32	40	60	4	17,5	49	84	M8	10	0,99	0,000572
6.5/38	83	58	14	38	24 - 28 - 32 - 38	40	80	4	18	48	84	M8	10	1,20	0,000877
8/42	92	65	14	42	25 - 28 - 32 - 38 - 42	42	110	4	18,5	51	88	M8	10	1,62	0,001467
12/48	100	68	19	48	32 - 38 - 42 - 48	50	110	4	27	50	104	M8	10	1,79	0,001869
30/65	142	96	19	65	38 - 42 - 48 - 55 - 60	70	140	4	35,5	73	144	M10	20	5,28	0,010542
40/80	175	124	-	80	-	90	-	6	46,5	93	186	M10	20	11,7	0,036774
100	210	152	36	100	-	110	-	8	63	102	228	M10	20	20,4	0,095742
125	270	192	45	125	-	140	-	10	78	134	290	M10	20	43,3	0,329397

\* = Up to size 2/24, set-screw is 180° from keyway; from size 3,5/28 set-screw is set onto the keyway.  
 \*\*= Values are for complete couplings, max bore diameter, only.

**Order form**

Hub **GDM 12/48 F32**

GDM: SITEX® hub

Size

L: long hub execution  
 F...: bore diameter

Manicotto **AD 12/48**

AD: SITEX® sleeve

Size

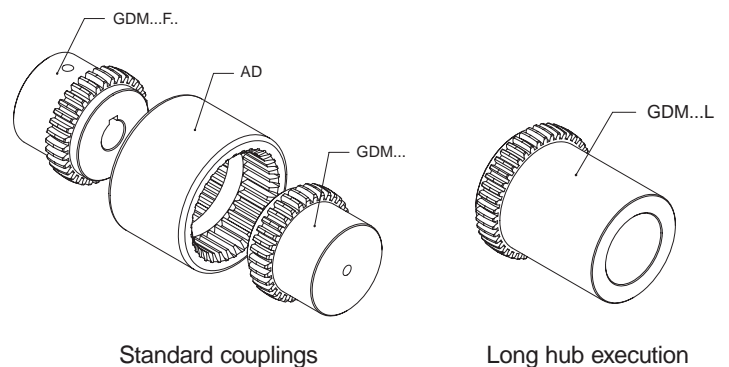

Standard couplings

Long hub execution

# SITEX® coupling selection

## Selection according to torque

The maximum starting torque of the driver or driven machine must not exceed the maximum torque capacity of SITEX®. With uniform loading and well aligned shafts, SITEX® can be

operated at all torques up to the maximum. In case of irregular torque, consider that the SITEX® coupling can bear peak loads up to 3 times the nominal torque indicated.

## Technical characteristics

Size	TKN [Nm]	TKmax [Nm]	TKw [Nm]	[kW]										n <sub>max</sub> [min <sup>-1</sup> ]	W [kg]	J [kg.m <sup>2</sup> ]	ΔK <sub>a</sub> [mm]	ΔK <sub>r</sub> [mm]	ΔK <sub>w</sub> [°]
				n = 500 [min <sup>-1</sup> ]		n = 750 [min <sup>-1</sup> ]		n = 1000 [min <sup>-1</sup> ]		n = 1500 [min <sup>-1</sup> ]		n = 3000 [min <sup>-1</sup> ]							
				std	max	std	max	std	max	std	max	std	max						
0,5/14	10	30	5	0,5	1,6	0,8	2,4	1,0	3,1	1,6	4,7	3,1	9,4	14.000	0,21	0,000026	±1	±0,3	+1
19	16	48	8	0,8	2,5	1,3	3,8	1,7	5,0	2,5	7,5	5,0	15,1	11.800	0,32	0,000047	±1	±0,3	±1
2/24	21	63	10,5	1,1	3,3	1,6	4,9	2,2	6,6	3,3	9,9	6,6	19,8	10.500	0,48	0,000093	±1	±0,3	±1
3,5/28	45	135	22,5	2,4	7,1	3,5	10,6	4,7	14,1	7,1	21,2	14,1	42,4	8.500	1,18	0,000309	±1	±0,4	±1
5/32	60	180	30	3,1	9,4	4,7	14,1	6,3	18,8	9,4	28,3	18,8	56,5	7.600	1,47	0,000548	±1	±0,4	±1
6,5/38	81	243	40,5	4,2	12,7	6,4	19,1	8,5	25,4	12,7	38,2	25,4	76,3	6.700	1,91	0,000868	±1	±0,4	±1
8/42	100	300	50	5,2	15,7	7,9	23,6	10,5	31,4	15,7	47,1	31,4	94,2	6.000	2,52	0,001428	±1	±0,4	±1
12/48	142	426	71	7,4	22,4	11,2	33,6	14,9	44,8	22,3	67,1	44,6	134,3	5.580	3,21	0,001838	±1	±0,4	±1
30/65	380	1140	190	19,9	59,7	29,8	89,5	39,8	119,4	59,7	179,1	119,4	358,1	4.000	8,86	0,010960	±1	±0,6	±1
40/80	700	2100	350	36,6	109,9	55,0	164,9	73,3	219,9	109,9	329,8	219,9	659,7	3.100	11,20	0,037100	±1	±0,7	±1
100	1210	3630	605	63,4	190,1	95,0	285,1	126,7	380,1	190,1	570,2	380,1	1140,3	3.000	198,80	0,096120	±1	±0,8	±1
125	2500	7500	1250	130,9	392,7	196,3	589,0	261,8	785,3	392,7	1178,0	-	-	2.100	41,30	0,328750	±1	±1,1	±1

The values shown in the table for radial and angular misalignment, must be corrected in case they are simultaneously acting on the coupling.

The sum of the admissible value (A) and the respective values shown in the table must be lower or equal to 1.

$$\frac{\Delta K_{rA}}{\Delta K_r} + \frac{\Delta K_{wA}}{\Delta K_w} \leq 1$$

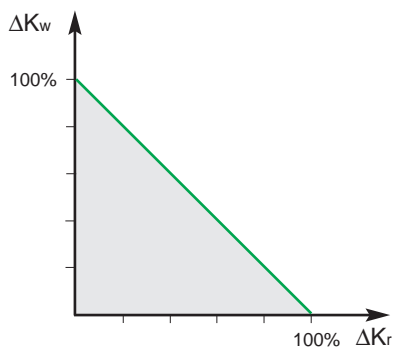

T <sub>KN</sub>	Coupling nominal torque	Nm
T <sub>Kmax</sub>	Coupling maximum torque	Nm
W	Weight	kg
J	Coupling moment of inertia	kgm <sup>2</sup>
ΔK <sub>a</sub>	Maximum axial misalignment	mm
ΔK <sub>r</sub>	Maximum radial misalignment	mm
ΔK <sub>w</sub>	Maximum angular misalignment	°
n <sub>max</sub>	Maximum rpm	min <sup>-1</sup>

## Mounting instructions

- Fix the hubs to the shafts, taking care to align the inner surfaces with the corresponding shaft ends.
- Insert the sleeve on the two hubs adjusting the distance (quote "b") of the same ones trying at the same time to align the two shafts as much as possible.

- Fix into position the two elements to be coupled.
- Before rotating the coupling, be sure the sleeve is free to move axially.

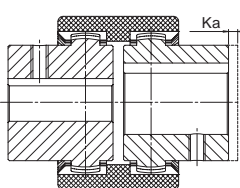

axial misalignment

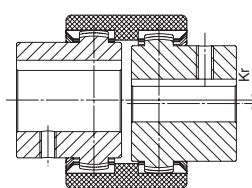

radial misalignment

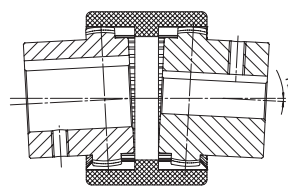

angular misalignment

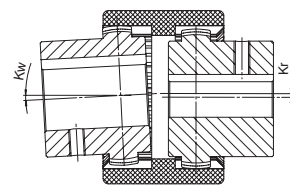

both angular and radial misalignment

## Tables for SITEX® couplings with taper or splined bores

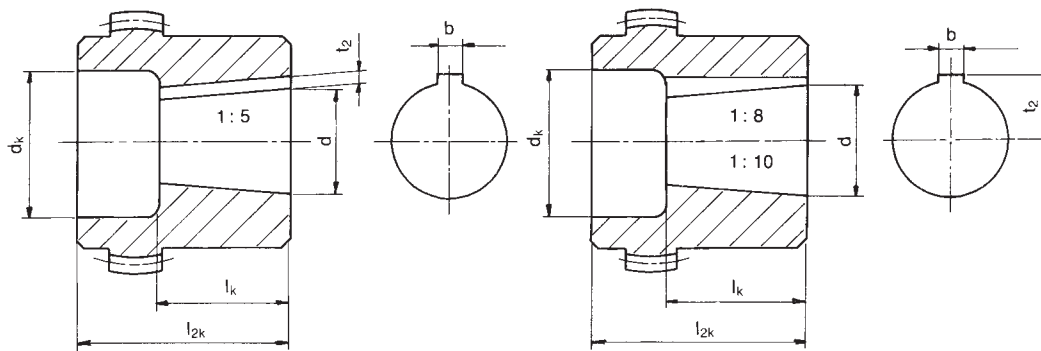

**Taper 1 : 5 for**  
BOSCH - BUCHER - LEDUC - DÜSTERLOH

Size	dø + 0,05	b <sup>JS9</sup>	t <sup>±0,1</sup>	l <sub>k</sub>	0,5/14		19		2/24		3,5/28		5/32		6,5/38		8/42		12/48		30/65	
					d <sub>k</sub>	l <sub>2k</sub>	d <sub>k</sub>	l <sub>2k</sub>	d <sub>k</sub>	l <sub>2k</sub>	d <sub>k</sub>	l <sub>2k</sub>	d <sub>k</sub>	l <sub>2k</sub>	d <sub>k</sub>	l <sub>2k</sub>	d <sub>k</sub>	l <sub>2k</sub>	d <sub>k</sub>	l <sub>2k</sub>	d <sub>k</sub>	l <sub>2k</sub>
a1	9,85	2	1	11,5	18	23	22	25	24	26	35	26	36	26	45	26						
a2	16,85	3	1,8	18,5			25	30	28	30	35	40	36	40	45	40	45	42	45	42	45	50
a3	19,85	4	2,2	21,5					28	36	35	40	36	40	45	40	45	42	45	42	45	50
a4	21,95	3	1,8	21,5					30	26	32	40	32	40	42	40	45	42				
a5	24,85	5	2,9	26,5							35	40	36	40	45	40	45	42	45	42	55	50
a6	29,85	6	2,6	31,5										45	55	45	55	45	55	55	55	55
a7	34,85	6	2,6	36,5														52	60	55	60	
a8	39,85	6	2,6	41,5														52	60	65	70	

**Taper 1 : 8 for**  
ATOS - CASAPPA - GARBE LAHMEYER - JOTTI & STROZZI - MARZOCCHI - SALAMI - SAUER-FLUID

Size	dø + 0,05	b <sup>JS9</sup>	t <sup>±0,1</sup>	l <sub>k</sub>	0,5/14		19		2/24		3,5/28		5/32		6,5/38		8/42		12/48		30/65	
					d <sub>k</sub>	l <sub>2k</sub>	d <sub>k</sub>	l <sub>2k</sub>	d <sub>k</sub>	l <sub>2k</sub>	d <sub>k</sub>	l <sub>2k</sub>	d <sub>k</sub>	l <sub>2k</sub>	d <sub>k</sub>	l <sub>2k</sub>	d <sub>k</sub>	l <sub>2k</sub>	d <sub>k</sub>	l <sub>2k</sub>	d <sub>k</sub>	l <sub>2k</sub>
b1	9,7	2,4	6	17	18	26	19	25	24	26	35	30	36	30	36	30						
b2	11,6	3	7,1	16,5	18	23			26	26	32	30										
b3	13	2,4	7,3	21					26	30	32	30			32	30						
b4	14	3	8,5	17,5	20	23	24	30	24	30	32	30	36	40								
b5	14,3	3,2	8,5	19,5																		
b6	17,287	3,2	9,6	24					28	35	32	40	36	40	42	40	45	42	45	42	45	50
b7	17,287	4	10,3	24					28	35	32	40	36	40	42	40	45	42	45	42	45	50
b8	17,287	3	9,7	24					28	35					42	40			45	42		
b9	22,002	3,99	12,4	28							32	40	36	40	42	40	45	42	45	42	55	50
b10	25,463	4,78	15,1	36							34	50	36	50	42	50	45	50	45	50	55	62
b11	25,463	5	15,5	36							34	50					45	50	45	50	55	62
b12	27	4,78	15,3	32,5											42	50						
b13	28,45	6	15,1	38,5											42	60	45	60				
b14	33,176	6,38	18,8	44											44	60	45	60	45	60	55	62
b15	33,176	7	18,8	44													45	60			55	62
b16	43,057	7,95	3,378	51																		
b17	41,15	8	3,1	42															48	60	55	60

**Taper 1 : 10 for**  
PARKER HANNIFIN NMF - TEVES

Size	dø + 0,05	b <sup>JS9</sup>	t <sup>±0,1</sup>	l <sub>k</sub>	0,5/14		19		2/24		3,5/28		5/32		6,5/38		8/42		12/48		30/65	
					d <sub>k</sub>	l <sub>2k</sub>	d <sub>k</sub>	l <sub>2k</sub>	d <sub>k</sub>	l <sub>2k</sub>	d <sub>k</sub>	l <sub>2k</sub>	d <sub>k</sub>	l <sub>2k</sub>	d <sub>k</sub>	l <sub>2k</sub>	d <sub>k</sub>	l <sub>2k</sub>	d <sub>k</sub>	l <sub>2k</sub>	d <sub>k</sub>	l <sub>2k</sub>
c1	19,95	5	12,1	32							35	50			42	50	45	50	45	50		
c2	24,95	6	14,1	45									36	55			45	60	45	60	55	60
c3	29,75	8	17	50													54	60	54	60	55	70

# SITEX® Nylex

SITEX Nylex couplings are made of 100% Polyamide.  
Two executions are available:

- **CV**: in 2 parts (1 hub and one sleeve including the hub);
- **C**: in 3 parts (2 hubs and one sleeve).

Designed for light applications, low cost and available with finished bore keyway and thread for set screw.  
Temperature range: - 25°C ÷ + 100°C

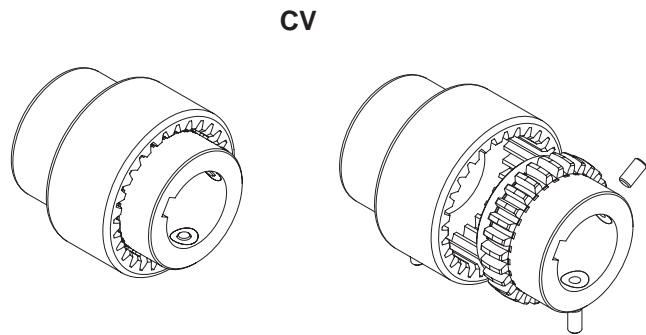
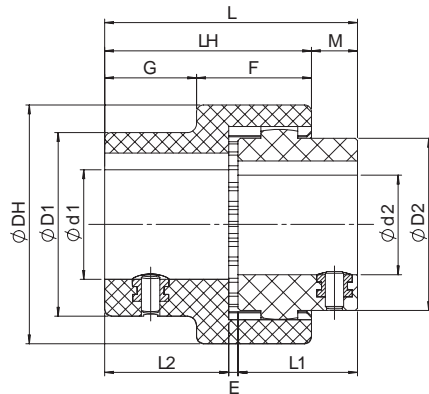

Size	d1 [mm]			D1 [mm]	d2 [mm]			D2 [mm]	DH [mm]	L1 [mm]	L2 [mm]	E [mm]	L [mm]	LH [mm]	M [mm]	F [mm]	G [mm]	TKN [Nm]	TKmax [Nm]	TKW [Nm]	nmax [min <sup>-1</sup> ]
	min	max	UNI keyway and stop screw [mm]		min	max	UNI keyway and stop screw [mm]														
0.5/14	6	14	14	25	6	12	7-9-10-11-12-14	26	40	23	23	2	48	40	8	23	17	5	10	2,5	6.000
19	14	19	18-19	31,5	14	19	14-17-19	40	48	25	25	2	52	42	9	23	19	8	16	4	6.000
2/24	10	24	19-20-24	37,5	10	24	10-14-16-19-20-24	40	52	26	26	2	54	45	10	25	20	12	24	6	6.000

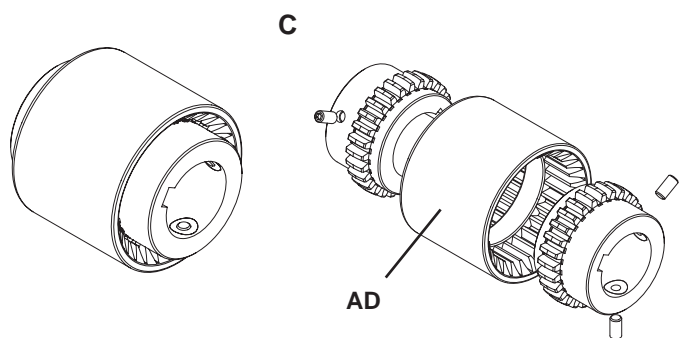
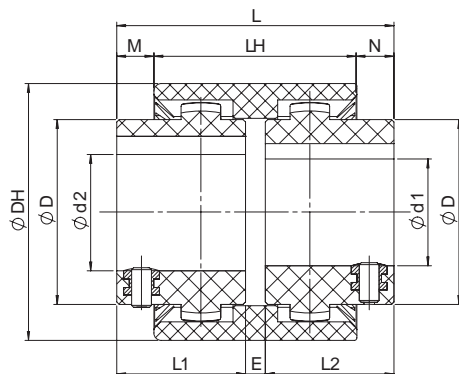

Taglia	d1-d2 [mm]			D [mm]	DH [mm]	L1 [mm]	L2 [mm]	E [mm]	L [mm]	LH [mm]	M [mm]	N [mm]	TKN [Nm]	TKmax [Nm]	TKW [Nm]	nmax [min <sup>-1</sup> ]
	min	max	UNI keyway and stop screw [mm]													
0.5/14	6	12	7-9-10-11-12-14	25	40	23	23	4	50	37	6,5	6,5	5	10	2,5	6.000
19	14	19	14-17-19	31,5	48	25	25	4	54	37	8,5	8,5	8	16	4	6.000
2/24	10	24	10-14-16-19-20-24	37,5	52	26	26	4	56	41	7,5	7,5	12	24	6	6.000

## Order form

Hub **GDN 05/14 F14**

GDN: SITEX NYLEX® hub  
GDNV: SITEX NYLEX® sleeve hub

Size \_\_\_\_\_

F...: bore diameter \_\_\_\_\_

C" execution sleeve **AD 2/24**

AD: SITEX NYLEX® sleeve

Size \_\_\_\_\_

T <sub>KN</sub>	Coupling nominal torque	Nm
T <sub>Kmax</sub>	Coupling maximum torque	Nm
T <sub>KW</sub>	Torque with reversal transmissible by the coupling	Nm
n <sub>max</sub>	Maximum rpm	min <sup>-1</sup>